

6-POLES ELECTROMECHANICAL MOTORS
MOTORES ELECTROMECÁNICOS 6 POLOS

MOT05-10

6-poles three-phase asynchronous motor, IP55 protection. Especially strong in cast iron with tropicalized winding made for external use. Protective cover for the oscillation control system in ABS with sealing gasket, protection level IP55.

Device for complete control of microswitches and connecting cables, and 2 cams for command of the independent regulation for the motor thrust.

Motor asíncrono trifásico 6 polos con protección IP55. Estructura particularmente robusta de fundición con bobinas tropicalizadas para uso exterior. Cáster de protección del sistema de control de la oscilación de ABS con junta de estanqueidad IP55. Dispositivo de control completo de microinterruptores y cables para cableado y doble leva de mando para la regulación independiente del impulso del motor.

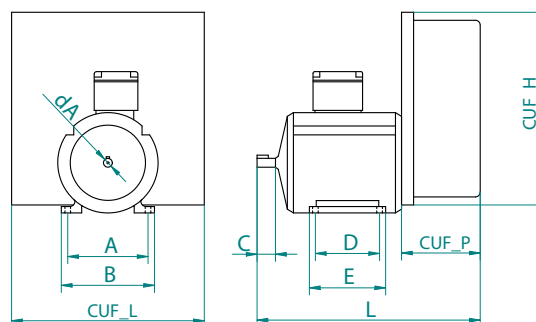

TECHNICAL CHARACTERISTICS

- 6P asynchronous three-phase motor protection IP55
- Protective cover in ABS of the swing control system
- Device of control with microswitches, wired cables and 2 control cams

CARACTERÍSTICAS TÉCNICAS

- Motor asíncrono trifásico 6 polos protección IP55
- Cáster de protección del sistema de control de la oscilación en ABS
- Dispositivo de control completo, con microinterruptores, cables de cableado y doble leva de mando

CODE	DESCRIPTION
MOT0504001	6P MOTOR 0,12 KW 2 CAMS REDUCTION - GEAR INCLUDED
MOT0504002	6P MOTOR 0,18 KW 2 CAMS REDUCTION - GEAR INCLUDED
MOT0504003	6P MOTOR 0,25 KW 2 CAMS REDUCTION - GEAR INCLUDED
MOT0504004	6P MOTOR 0,37 KW 2 CAMS REDUCTION - GEAR INCLUDED
MOT0504005	6P MOTOR 0,55 KW 2 CAMS REDUCTION - GEAR INCLUDED
MOT0504006	6P MOTOR 0,75 KW 2 CAMS REDUCTION - GEAR INCLUDED
MOT0504007	6P MOTOR 1,10 KW 2 CAMS REDUCTION - GEAR INCLUDED
MOT0504008	6P MOTOR 1,50 KW 2 CAMS REDUCTION - GEAR INCLUDED
MOT0504009	6P MOTOR 1,70 KW 2 CAMS REDUCTION - GEAR INCLUDED

6-POLES ELECTROMECHANICAL MOTORS
MOTORES ELECTROMECÁNICOS 6 POLOS

MOT05-10

MOT1004001	6P MOTOR 0,12 KW 2 C REDUCTION - GEAR INCLUDED AND COMMAND BOX
MOT1004003	6P MOTOR 0,18 KW 2 C REDUCTION - GEAR INCLUDED AND COMMAND BOX
MOT1004005	6P MOTOR 0,25 KW 2 C REDUCTION - GEAR INCLUDED AND COMMAND BOX
MOT1004007	6P MOTOR 0,37 KW 2 C REDUCTION - GEAR INCLUDED AND COMMAND BOX
MOT1004009	6P MOTOR 0,55 KW 2 C REDUCTION - GEAR INCLUDED AND COMMAND BOX
MOT1004011	6P MOTOR 0,75 KW 2 C REDUCTION - GEAR INCLUDED AND COMMAND BOX
MOT1004013	6P MOTOR 1,10 KW 2 C REDUCTION - GEAR INCLUDED AND COMMAND BOX
MOT1004015	6P MOTOR 1,50 KW 2 C REDUCTION - GEAR INCLUDED AND COMMAND BOX
MOT1004017	6P MOTOR 1,70 KW 2 C REDUCTION - GEAR INCLUDED AND COMMAND BOX
MOT1004002	6P MOTOR 0,12 KW 2 C REDUCTION - GEAR INCLUDED WIRED COMMAND BOX
MOT1004004	6P MOTOR 0,18 KW 2 C REDUCTION - GEAR INCLUDED WIRED COMMAND BOX
MOT1004006	6P MOTOR 0,25 KW 2 C REDUCTION - GEAR INCLUDED WIRED COMMAND BOX
MOT1004008	6P MOTOR 0,37 KW 2 C REDUCTION - GEAR INCLUDED WIRED COMMAND BOX
MOT1004010	6P MOTOR 0,55 KW 2 C REDUCTION - GEAR INCLUDED WIRED COMMAND BOX
MOT1004012	6P MOTOR 0,75 KW 2 C REDUCTION - GEAR INCLUDED WIRED COMMAND BOX
MOT1004014	6P MOTOR 1,10 KW 2 C REDUCTION - GEAR INCLUDED WIRED COMMAND BOX
MOT1004016	6P MOTOR 1,50 KW 2 C REDUCTION - GEAR INCLUDED WIRED COMMAND BOX
MOT1004018	6P MOTOR 1,70 KW 2 C REDUCTION - GEAR INCLUDED WIRED COMMAND BOX

MOT05-10 DIMENSIONS TABLE
 TABLA DIMENSIONES MOT05-10

CODE	A	B	C	D	E	L	dA	CUF_L	CUF_H	CUF_P
MOT0504001 MOT1004001 MOT1004002	100	116	23	80	95	250	11	240	240	98
MOT0504002 MOT1004003 MOT1004004 MOT0504003 MOT1004005 MOT1004006	112	132	30	90	113,5	270	14	240	240	98
MOT0504004 MOT1004007 MOT1004008 MOT0504005 MOT1004009 MOT1004010	125	149	40	100	125,5	290	19	240	240	98
MOT0504006 MOT1004011 MOT1004012	140	164	50	100	131	320	24	240	240	98
MOT0504007 MOT1004013 MOT1004014	140	164	50	125	156	345	24	240	240	98
MOT0504008 MOT1004015 MOT1004016 MOT0504009 MOT1004017 MOT1004018	160	188	60	140	173	380	24	240	240	98

TABLE BELL/MOTOR/SPROCKET – TABLA CAMPANA/MOTOR/PIÑÓN
MOT05-10

TONE	ANGLO-SAXON TONE	BELL DIAMETER (mm)	WEIGHT (Kg)	FALLING CLAPPER BELL 6P MOTOR (KW)	SPROCKET Z*	FLYING CLAPPER BELL 6P MOTOR (KW)	SPROCKET*
SOL	G2	</ = 470	</ = 60	0,12/0,18 KW MOT0504001 MOT0504002 MOT1004001 MOT1004002 MOT1004003 MOT1004004	10	0,12/0,18 KW MOT0504001 MOT0504002 MOT1004001 MOT1004002 MOT1004003 MOT1004004	10
SOLb	Fis2	500	72	0,18 KW MOT0504002 MOT1004003 MOT1004004	10	0,18 KW MOT0504002 MOT1004003 MOT1004004	10
FA	F2	530	85	0,18 KW MOT0504002 MOT1004003 MOT1004004	11	0,18 KW MOT0504002 MOT1004003 MOT1004004	10
MI	E2	560	100	0,18 KW MOT0504002 MOT1004003 MOT1004004	11	0,18 KW MOT0504002 MOT1004003 MOT1004004	10
Mlb	Dis2	595	120	0,18 KW MOT0504002 MOT1004003 MOT1004004	12	0,25 KW MOT0504003 MOT1004005 MOT1004006	11
RE	D2	630	140	0,25 KW MOT0504003 MOT1004005 MOT1004006	12	0,25 KW MOT0504003 MOT1004005 MOT1004006	11
REb	Cis2	665	170	0,25 KW MOT0504003 MOT1004005 MOT1004006	12	0,25 KW MOT0504003 MOT1004005 MOT1004006	11
DO	C2	705	200	0,25 KW MOT0504003 MOT1004005 MOT1004006	14	0,25 KW MOT0504003 MOT1004005 MOT1004006	11
SI	B1	750	245	0,25 KW MOT0504003 MOT1004005 MOT1004006	14	0,37 KW MOT0504004 MOT1004007 MOT1004008	12
Sib	Ais1	795	290	0,37 KW MOT0504004 MOT1004007 MOT1004008	14	0,37 KW MOT0504004 MOT1004007 MOT1004008	12
LA	A1	840	340	0,37 KW MOT0504004 MOT1004007 MOT1004008	14	0,37 KW MOT0504004 MOT1004007 MOT1004008	12

* Approximate data calculated according to the following ratio: bell wheel diameter equal to 130% of the bell diameter (falling clapper bell) or 110% (flying clapper bell).
Datos indicativos calculados según la siguiente relación: diámetro rueda igual al 130% (bandoe contrapesado) o 110% (bandoe) del diámetro de la campana.

TABLE BELL/MOTOR/SPROCKET – TABLA CAMPANA/MOTOR/PIÑÓN
MOT05-10

Lab	Gis1	890	410	0,37 KW MOT0504004 MOT1004007 MOT1004008	14	0,37 KW MOT0504004 MOT1004007 MOT1004008	12
SOL	G1	945	480	0,37 KW MOT0504004 MOT1004007 MOT1004008	16	0,55 KW MOT0504005 MOT1004009 MOT1004010	14
SOLb	Fis1	1000	550	0,55 KW MOT0504005 MOT1004009 MOT1004010	16	0,55 KW MOT0504005 MOT1004009 MOT1004010	14
FA	F1	1060	680	0,55 KW MOT0504005 MOT1004009 MOT1004010	16	0,55 KW MOT0504005 MOT1004009 MOT1004010	14
MI	E1	1120	810	0,55 KW MOT0504005 MOT1004009 MOT1004010	16	0,75 KW MOT0504006 MOT1004011 MOT1004012	14
Mlb	Dis1	1185	980	0,75 KW MOT0504006 MOT1004011 MOT1004012	18	0,75 KW MOT0504006 MOT1004011 MOT1004012	14
RE	D1	1255	1200	0,75 KW MOT0504006 MOT1004011 MOT1004012	18	1,10 KW MOT0504007 MOT1004013 MOT1004014	16
REb	Cis1	1330	1400	1,10 KW MOT0504007 MOT1004013 MOT1004014	18	1,10 KW MOT0504007 MOT1004013 MOT1004014	16
DO	C1	1410	1680	1,10 KW MOT0504007 MOT1004013 MOT1004014	18	1,50 KW MOT0504008 MOT1004015 MOT1004016	16
SI	B0	1495	1950	1,50 KW MOT0504008 MOT1004015 MOT1004016	21	1,50 KW MOT0504008 MOT1004015 MOT1004016	18
Sib	Ais0	1580	2300	1,50 KW MOT0504008 MOT1004015 MOT1004016	21	1,70 KW MOT0504009 MOT1004017 MOT1004018	18

* Approximate data calculated according to the following ratio: bell wheel diameter equal to 130% of the bell diameter (falling clapper bell) or 110% (flying clapper bell).
Datos indicativos calculados según la siguiente relación: diámetro rueda igual al 130% (bandoe contrapesado) o 110% (bandoe) del diámetro de la campana.

8-POLES MOTORS WITH GEAR BOX AND ELECTROMAGNETIC BRAKE MOTORES 8 POLOS CON REDUCTOR MECÁNICO Y FRENO ELECTROMAGNÉTICO MOT25

8-poles three-phase asynchronous motor with electromagnetic brake 24 VDC. Especially strong in cast iron with tropicalized winding made for external use (IP55 protection). Junction box containing all the wiring, IP55 protection. Protective cover in PVC of the swing control system. Device for complete control of microswitches and connecting cables, and cam for command of the independent regulation for the thrust of the motor and the brake action.

Motor asíncrono trifásico 8 polos con freno electromagnético 24 VCC. Estructura de fundición particularmente robusta con bobinas tropicalizadas para uso exterior, protección IP55. Caja de derivación con todo el cableado, protección IP55. Cáster de protección del sistema de control de la oscilación de PVC. Dispositivo de control completo con microinterruptores, cables de cableado y levas de mando para la regulación independiente del impulso del motor y de la intervención del freno.

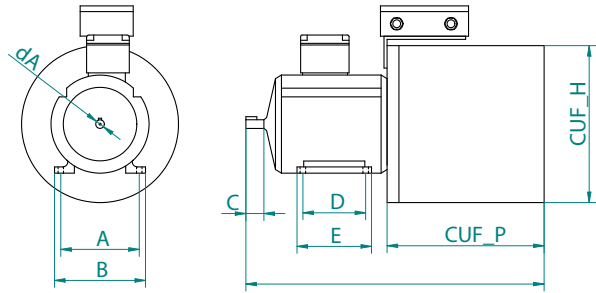

CODE	DESCRIPTION
MOT2504001	8P MOTOR 0,25KW 4C REDUCTION-GEAR AND ELECTROMAGNETIC BRAKE
MOT2504002	8P MOTOR 0,25KW 6C REDUCTION-GEAR AND ELECTROMAGNETIC BRAKE
MOT2504005	8P MOTOR 0,55KW 4C REDUCTION-GEAR AND ELECTROMAGNETIC BRAKE
MOT2504006	8P MOTOR 0,55KW 6C REDUCTION-GEAR AND ELECTROMAGNETIC BRAKE
MOT2504009	8P MOTOR 1,10KW 4C REDUCTION-GEAR AND ELECTROMAGNETIC BRAKE
MOT2504010	8P MOTOR 1,10KW 6C REDUCTION-GEAR AND ELECTROMAGNETIC BRAKE

DIMENSIONS TABLE / TABLA DIMENSIONES

CODE	A	B	C	D	E	L	dA	CUF_L	CUF_H	CUF_P
MOT2504001 MOT2504002	125	149	40	100	125,5	450	19	200	200	210
MOT2504005 MOT2504006	140	164	50	125	156	497	24	200	200	210
MOT2504009 MOT2504010	160	188	60	140	173	536	28	250	250	210

TABLE BELL/MOTOR/SPROCKET – TABLA CAMPANA/MOTOR/PIÑÓN

TONE	ANGLO-SAXON TONE	BELL DIAMETER (mm)	WEIGHT (Kg)	8P MOTOR (KW)	SPROCKET Z*
FA - SI	F2 - B1	530 - 750	85 - 245	0,25 KW MOT2504001 MOT2504002	14 - 18
Sib - FA	AIS1 - F1	795 - 1060	290 - 680	0,55 KW MOT2504005 MOT2504006	18 - 24
MI - DO	E1 - C1	1120 - 1410	810 - 1680	1,1 KW MOT2504009 MOT250401	21 - 32

* Approximate data calculated according to the following ratio: bell wheel diameter equal to 170% of the bell diameter.
Datos indicativos calculados en base a la siguiente relación: diámetro rueda igual al 170% del diámetro de la campana.

ECATRON – ELECTRONIC MOTORS FOR SWINGING BELLS MOTORES ELECTRÓNICOS ECATRON PARA MOVIMIENTO CAMPANAS

MOT15

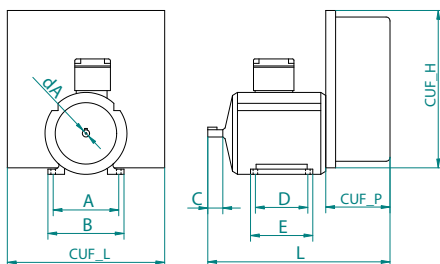

Revolutionary system for the bell ringing that combine electronic technology with tradition, and complete respect for the church, bell tower and bells. ECATRON offers these unquestionable advantages:

SAFETY:

- Reduction of the effort of pushing
- Protection of the support structures against stresses (framework, headstock or yoke)
- Protection of the bell tower (reduction of stresses)
- Emergency brake in case of malfunctions

INNOVATIVE:

- 220 VAC single-phase power supply: the three-phase is generated automatically
- Control of all of the most commonly used kinds of ringing: falling/flying clapper bell, tollings etc.
- Use of low-power standard motors
- Elimination of the electrical board in the bell tower
- Regulation of sound parameters via simple commands
- Self-diagnosis of the working compatibly with existing systems
- Self-regulation that works independently of consumption and working temperature with automatic electronic protection against overheating and malfunctions
- Braking of the bell for a quick stop of the ringing

RESPECT FOR TRADITION:

- Complete quality of the manual ringing
- Possibility of special ringing that needs the synchronization of the bells
- Use of particular devices such as bell clapper stop, synchronized chiming

TECHNICAL CHARACTERISTICS

- 6P asynchronous three-phase motor, IP55 protection
- ABS protective case of the system control
- 220 VAC power supply
- Additional programmable relay outputs

Revolucionario sistema para el sonido de las campanas uniendo electrónica y tradición, en el absoluto respeto de iglesias, campanarios y campanas. ECATRON ofrece indudables ventajas:

SEGURIDAD:

- Disminución de los esfuerzos de impulso
- Protección contra esfuerzos de las estructuras de sostén (andamios - yugos)
- Protección del campanario (reducción de las vibraciones)
- Freno de emergencia para eventuales anomalías de funcionamiento

INNOVACIÓN:

- Alimentación 220 VCA monofásica: la trifásica se genera automáticamente
- Control de todos los tipos de sonido más comunes: bandedo normal, alto, volteo, vaso, al vuelo etc.
- Uso de motores estándar con potencia reducida
- Eliminación del tablero en el campanario
- Regulación de los parámetros de sonido mediante simples mandos
- Autodiagnóstico de funcionamiento y compatibilidad con los sistemas existentes
- Autoregulación independiente del desgaste y de la temperatura de funcionamiento con protección electrónica automática para recalentamientos y anomalías de funcionamiento
- Freno de la campana para una rápida detención del sonido

RESPECTO DE LA TRADICIÓN:

- Calidad absoluta del sonido manual
- Posibilidad de sonidos especiales que requieren la sincronización de las campanas
- Uso de dispositivos particulares como el que permite detener el badajo o hacer repiques sincronizados

CARACTERÍSTICAS TÉCNICAS

- Motor asíncrono trifásico 6 polos protección IP55
- Cáster de protección del sistema de control de ABS
- Alimentación 220 VCA
- Salidas suplementarias con relés programables

CODE	DESCRIPTION
MOT1504001	6P MOTOR 0,18 KW ECATRON WITH ELECTRONIC ON BOARD
MOT1504002	6P MOTOR 0,25 KW ECATRON WITH ELECTRONIC ON BOARD
MOT1504003	6P MOTOR 0,37 KW ECATRON WITH ELECTRONIC ON BOARD
MOT1504004	6P MOTOR 0,55 KW ECATRON WITH ELECTRONIC ON BOARD
MOT1504005	6P MOTOR 0,75 KW ECATRON WITH ELECTRONIC ON BOARD
MOT1504006	6P MOTOR 1,10 KW ECATRON WITH ELECTRONIC ON BOARD
MOT1504020	6P MOTOR 0,18 KW ECATRON SEPARATE ELECTRONIC
MOT1504021	6P MOTOR 0,25 KW ECATRON SEPARATE ELECTRONIC
MOT1504022	6P MOTOR 0,37 KW ECATRON SEPARATE ELECTRONIC
MOT1504023	6P MOTOR 0,55 KW ECATRON SEPARATE ELECTRONIC
MOT1504024	6P MOTOR 0,75 KW ECATRON SEPARATE ELECTRONIC
MOT1504025	6P MOTOR 1,10 KW ECATRON SEPARATE ELECTRONIC

ECATRON DIMENSIONS TABLE / TABLA DIMENSIONES MOTOR ECATRON

CODE	A	B	C	D	E	L	dA	CUF_L	CUF_H	CUF_P
MOT1504001 MOT1504020	112	132	30	90	113,5	270	14	240	240	98
MOT1504002 MOT1504021	112	132	30	90	113,5	270	14	240	240	98
MOT1504003 MOT1504022	125	149	40	100	125,5	290	19	240	240	98
MOT1504004 MOT1504023	125	149	40	100	125,5	290	19	240	240	98
MOT1504005 MOT1504024	140	164	50	125	156	345	24	240	240	98
MOT1504006 MOT1504025	160	188	60	140	173	380	24	240	240	98

TABLE BELL/MOTOR/SPROCKET – TABLA CAMPANA/MOTOR/PIÑÓN

FALLING CLAPPER – VOLTEO
BANDEO CONTRAPESADO – VOLTEO

STONE FROM TO	ANGLO-SAXON TONE FROM TO	WEIGHT (KG) FROM TO	6P MOTOR EQUIPPED WITH ECATRON (KW)	SPROCKET Z*
FA DO	F3 C2	12 200	0,18 KW MOT1504001 MOT1504020	10
SI SOL	B1 G1	245 480	0,25 KW MOT1504002 MOT1504021	12
SOLb Mlb	Fis1 Dis1	550 980	0,37 KW MOT1504003 MOT1504022	14
RE DO	D1 C1	1200 1680	0,55KW MOT1504004 MOT1504023	16
SI LA	B0 A0	1950 2800	0,75 KW MOT1504005 MOT1504024	16
LAB SOL	Gis0 G0	3300 3900	1,10 KW MOT1504006 MOT1504025	18

FLYING CLAPPER
BANDEO

STONE FROM TO	ANGLO-SAXON TONE FROM TO	WEIGHT (KG) FROM TO	6P MOTOR EQUIPPED WITH ECATRON (KW)	SPROCKET Z*
FA REb	F3 Cis2	12 170	0,18 KW MOT1504001 MOT1504020	10
DO LA	C2 A1	200 340	0,25 KW MOT1504002 MOT1504021	12
LAB SOLb	Gis1 Fis1	410 550	0,37 KW MOT1504003 MOT1504022	14
FA MI	F1 E1	680 800	0,55KW MOT1504004 MOT1504023	14
Mlb RE	Dis1 D1	980 1140	0,75 KW MOT1504005 MOT1504024	16
REb SI	Cis1 B0	1400 1950	1,10 KW MOT1504006 MOT1504025	16

* Approximate data calculated according to the following ratio: bell wheel diameter equal to 130% of the bell diameter (falling clapper bell), 170% (volteo) or 110% (flying clapper).

Datos indicativos calculados en base a la siguiente relación: bandeo contrapesado: diámetro rueda igual al 130% del diámetro de la campana; volteo: diámetro rueda igual al 170% del diámetro de la campana; bandeo: diámetro rueda igual al 110% del diámetro de la campana.

BELL SWINGING LINEAR MOTORS MOTOR LINEAL PARA MOVIMIENTO CAMPANAS MOT30

These bell swinging linear motors do not need a chain or any other physical connection with the bell, the movement is transmitted magnetically. It is extremely silent and requires very little maintenance thanks to the absence of moving mechanical parts subject to wear. The installation kit includes everything necessary for the installation: inductor, rotor, power controller and sensor for the movement. Thanks to the linear motor we guarantee efficiency and excellent value for money without losing traditional sound performance. We propose different versions depending on the weight of the bell (up to 2500 kg).

Motor lineal para movimiento campanas. No necesita cadena u otras conexiones físicas con la campana porque el movimiento se transmite magnéticamente. Es extremadamente silencioso y necesita muy poco mantenimiento gracias a la ausencia de partes mecánicas en movimiento sujetas a desgaste. El kit de instalación comprende todo lo necesario para el montaje: el inductor, el inducido, el control de potencia y el sensor de movimiento. El motor lineal garantiza eficiencia y una excelente relación calidad-precio sin perder las características del sonido tradicional. Tenemos a disposición diferentes versiones según el peso de la campana (hasta 2500 kg).

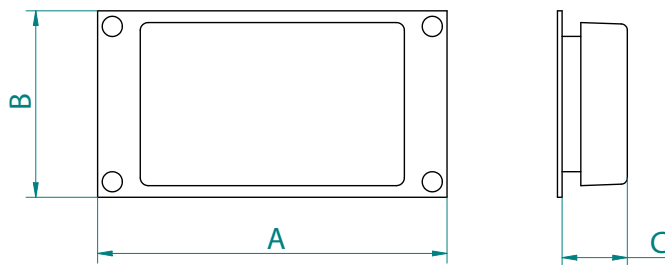
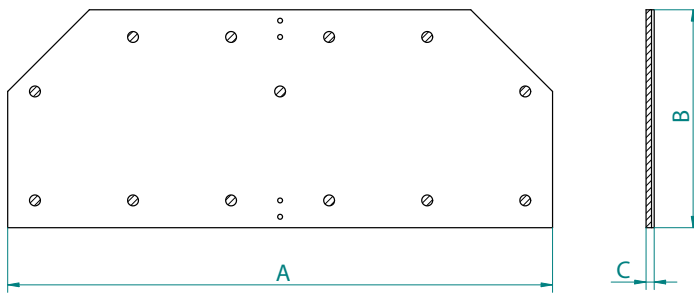

**BELL SWINGING LINEAR MOTORS
MOTOR LINEAL PARA MOVIMIENTO CAMPANAS
MOT30**

CODE	DESCRIPTION
MOT3004001	LINEAR MOTOR KIT 380V FOR BELLS UP TO 60 KG (132 LB)
MOT3004002	LINEAR MOTOR KIT 220V FOR BELLS UP TO 30 KG (66 LB)
MOT3004003	LINEAR MOTOR KIT 380V FOR BELLS UP TO 100 KG (220 LB)
MOT3004004	LINEAR MOTOR KIT 220V FOR BELLS UP TO MAX 70 KG (154 LB)
MOT3004005	LINEAR MOTOR KIT 380V FOR BELLS UP TO MAX 250 KG (551 LB)
MOT3004006	LINEAR MOTOR KIT 220V FOR BELLS UP TO MAX 100 KG (220 LB)
MOT3004007	LINEAR MOTOR KIT 380V FOR BELLS UP TO MAX 400 KG (881 LB)
MOT3004008	LINEAR MOTOR KIT 220V FOR BELLS UP TO MAX 400 KG (881 LB)
MOT3004009	LINEAR MOTOR KIT 380V FOR BELLS UP TO MAX 700KG (1543 LB)
MOT3004010	LINEAR MOTOR KIT 380V FOR BELLS UP TO MAX 1000 KG (2204 LB)
MOT3004011	LINEAR MOTOR KIT 380V FOR BELLS UP TO MAX 1300 KG (2866 LB)
MOT3004012	LINEAR MOTOR KIT 380V FOR BELLS UP TO 2500 KG (5511 LB)

GEAR BOX REDUCTORES PARA MOTORES MOVIMIENTO CAMPANAS RID05-10-15

Device to be applied to the electric motors for the thrust control for the swinging of the bells. Simple and strong construction that is easily adjustable to any type of motor. Maintenance free. Two types of reduction available with a maximum of 4 cams to satisfy all requirements of ringing.

Dispositivo que se aplica a los motores eléctricos para controlar los impulsos necesarios a la oscilación de las campanas. De simple y robusta construcción y fácilmente adaptable a cualquier tipo de motor. No requiere ningún tipo de mantenimiento. Se proponen con dos tipos de reducción y con un máximo de 4 levas para satisfacer todas las exigencias de sonido.

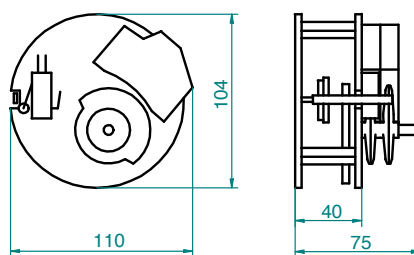

CODE	DESCRIPTION
RID0504001	GEAR BOX 1:20 1 CAM
RID0504002	GEAR BOX 1:20 2 CAMS
RID0504003	GEAR BOX 1:20 3 CAMS
RID0504004	GEAR BOX 1:20 4 CAMS
RID1004001	GEAR BOX 1:32 1.CAM CONCERT
RID1004002	GEAR BOX 1:32 2.CAMS CONCERT
RID1004003	GEAR BOX 1:32 3.CAMS CONCERT
RID1004004	GEAR BOX 1:32 4.CAMS CONCERT
RID1004005	GEAR BOX 1:32 6 CAMS CONCERT
RID1504001	GEAR BOX 1:8 1 CAM
RID1504002	GEAR BOX 1:8 2 CAMS
RID1504003	GEAR BOX 1:8 3 CAMS
RID1504004	GEAR BOX 1:8 4 CAMS

SPROCKETS / PIÑONES

PIGZ 8-9-10-11-12-14-16-18-21-24-26-28-30-32-34-36-38-40

The number of sprocket's cogs is usually defined with "Z" followed by the number of cogs. Sprockets are employed to transmit through a chain the swinging movement from motor to bell. That element is very important because, if the sprocket is connected to the motor, the speed is directly proportionate to the number of cogs.

Los piñones sirven para transmitir el movimiento oscilatorio desde el motor a la campana por medio de una cadena.

Generalmente, el número de dientes del piñón se indica tras la letra Z (por ej. 8 dientes = Z8). Este dato es fundamental porque la velocidad es directamente proporcional al número de dientes.

CODE	DESCRIPTION
PIG-Z8/11/316	SPROCKET Z8 D.11X3/16"
PIG-Z9/11/316	SPROCKET Z9 D.11X3/16"
PIG-Z10/14/316	SPROCKET Z10 D.14X3/16"
PIG-Z10/14/516	SPROCKET Z10 D.14X5/16"
PIG-Z11/14/316	SPROCKET Z11 D.14X3/16"
PIG-Z11/14/516	SPROCKET Z11 D.14X5/16"
PIG-Z12/14/316	SPROCKET Z12 D.14X3/16"
PIG-Z12/14/516	SPROCKET Z12 D.14X5/16"
PIG-Z12/19/316	SPROCKET Z12 D.19X3/16"
PIG-Z12/19/516	SPROCKET Z12 D.19X5/16"
PIG-Z14/14/316	SPROCKET Z14 D.14X3/16"
PIG-Z14/14/516	SPROCKET Z14 D.14X5/16"
PIG-Z14/19/316	SPROCKET Z14 D.19X3/16"
PIG-Z14/19/516	SPROCKET Z14 D.19X5/16"
PIG-Z14/24/316	SPROCKET Z14 D.24X3/16"
PIG-Z14/24/516	SPROCKET Z14 D.24X5/16"
PIG-Z16/14/316	SPROCKET Z16 D.14X3/16"
PIG-Z16/14/516	SPROCKET Z16 D.14X5/16"
PIG-Z16/19/316	SPROCKET Z16 D.19X3/16"
PIG-Z16/19/516	SPROCKET Z16 D.19X5/16"
PIG-Z16/24/316	SPROCKET Z16 D.24X3/16"
PIG-Z16/24/516	SPROCKET Z16 D.24X5/16"
PIG-Z18/14/316	SPROCKET Z18 D.14X3/16"
PIG-Z18/14/516	SPROCKET Z18 D.14X5/16"
PIG-Z18/19/316	SPROCKET Z18 D.19X3/16"
PIG-Z18/19/516	SPROCKET Z18 D.19X5/16"
PIG-Z18/24/316	SPROCKET Z18 D.24X3/16"
PIG-Z18/24/516	SPROCKET Z18 D.24X5/16"
PIG-Z18/28/516	SPROCKET Z18 D.28X5/16"
PIG-Z21/19/316	SPROCKET Z21 D.19X3/16"
PIG-Z21/19/516	SPROCKET Z21 D.19X5/16"
PIG-Z21/24/316	SPROCKET Z21 D.24X3/16"
PIG-Z21/24/516	SPROCKET Z21 D.24X5/16"
PIG-Z21/28/516	SPROCKET Z21 D.28X5/16"
PIG-Z24/19/316	SPROCKET Z24 D.19X3/16"
PIG-Z24/19/516	SPROCKET Z24 D.19X5/16"
PIG-Z24/24/316	SPROCKET Z24 D.24X3/16"
PIG-Z24/24/516	SPROCKET Z24 D.24X5/16"
PIG-Z24/28/516	SPROCKET Z24 D.28X5/16"
PIG-Z26/28/516	SPROCKET Z26 D.28X5/16"
PIG-Z28/28/516	SPROCKET Z28 D.28X5/16"
PIG-Z30/28/516	SPROCKET Z30 D.28X5/16"
PIG-Z32/28/516	SPROCKET Z32 D.28X5/16"
PIG-Z34/28/516	SPROCKET Z34 D.28X5/16"
PIG-Z36/28/516	SPROCKET Z36 D.28X5/16"
PIG-Z38/28/516	SPROCKET Z38 D.28X5/16"
PIG-Z40/28/516	SPROCKET Z40 D.28X5/16"

TABLE OF PRODUCT CODES

CODE	DESCRIPTION
MOT0504001	6P MOTOR 0.12KW 2 CAMS REDUCTION-GEAR INCLUDED
MOT0504002	6P MOTOR 0.18KW 2 CAMS REDUCTION-GEAR INCLUDED
MOT0504003	6P MOTOR 0.25KW 2 CAMS REDUCTION-GEAR INCLUDED
MOT0504004	6P MOTOR 0.37KW 2 CAMS REDUCTION-GEAR INCLUDED
MOT0504005	6P MOTOR 0.55KW 2 CAMS REDUCTION-GEAR INCLUDED
MOT0504006	6P MOTOR 0.75KW 2 CAMS REDUCTION-GEAR INCLUDED
MOT0504007	6P MOTOR 1.10KW 2 CAMS REDUCTION-GEAR INCLUDED
MOT0504008	6P MOTOR 1.50KW 2 CAMS REDUCTION-GEAR INCLUDED
MOT0504009	6P MOTOR 1.70KW 2 CAMS REDUCTION-GEAR INCLUDED
MOT1004001	6P MOTOR 0.12KW 2 C REDUCTION-GEAR INCLUDED AND COMMAND BOX
MOT1004002	6P MOTOR 0.12KW 2C REDUCTION-GEAR INCLUDED WIRED COMMAND BOX
MOT1004003	6P MOTOR 0.18KW 2 C REDUCTION-GEAR INCLUDED AND COMMAND BOX
MOT1004004	6P MOTOR 0.18KW 2C REDUCTION-GEAR INCLUDED WIRED COMMAND BOX
MOT1004005	6P MOTOR 0.25KW 2 C REDUCTION-GEAR INCLUDED AND COMMAND BOX
MOT1004006	6P MOTOR 0.25KW 2C REDUCTION-GEAR INCLUDED WIRED COMMAND BOX
MOT1004007	6P MOTOR 0.37KW 2 C REDUCTION-GEAR INCLUDED AND COMMAND BOX
MOT1004008	6P MOTOR 0.37KW 2C REDUCTION-GEAR INCLUDED WIRED COMMAND BOX
MOT1004009	6P MOTOR 0.55KW 2 C REDUCTION-GEAR INCLUDED AND COMMAND BOX
MOT1004010	6P MOTOR 0.55KW 2C REDUCTION-GEAR INCLUDED WIRED COMMAND BOX
MOT1004011	6P MOTOR 0.75KW 2 C REDUCTION-GEAR INCLUDED AND COMMAND BOX
MOT1004012	6P MOTOR 0.75KW 2C REDUCTION-GEAR INCLUDED WIRED COMMAND BOX
MOT1004013	6P MOTOR 1.10KW 2 C REDUCTION-GEAR INCLUDED AND COMMAND BOX
MOT1004014	6P MOTOR 1.10KW 2C REDUCTION-GEAR INCLUDED WIRED COMMAND BOX
MOT1004015	6P MOTOR 1.50KW 2 C REDUCTION-GEAR INCLUDED AND COMMAND BOX
MOT1004016	6P MOTOR 1.50KW 2C REDUCTION-GEAR INCLUDED WIRED COMMAND BOX
MOT1004017	6P MOTOR 1.70KW 2 C REDUCTION-GEAR INCLUDED AND COMMAND BOX
MOT1004018	6P MOTOR 1.70KW 2C REDUCTION-GEAR INCLUDED WIRED COMMAND BOX
MOT2504001	8P MOTOR 0,25KW 4C REDUCTION-GEAR AND ELECTROMAGNETIC BRAKE
MOT2504002	8P MOTOR 0,25KW 6C REDUCTION-GEAR AND ELECTROMAGNETIC BRAKE
MOT2504005	8P MOTOR 0,55KW 4C REDUCTION-GEAR AND ELECTROMAGNETIC BRAKE
MOT2504006	8P MOTOR 0,55KW 6C REDUCTION-GEAR AND ELECTROMAGNETIC BRAKE
MOT2504009	8P MOTOR 1,10KW 4C REDUCTION-GEAR AND ELECTROMAGNETIC BRAKE
MOT2504010	8P MOTOR 1,10KW 6C REDUCTION-GEAR AND ELECTROMAGNETIC BRAKE
MOT1504001	6P MOTOR 0.18KW ECATRON WITH ELECTRONIC ON BOARD
MOT1504002	6P MOTOR 0.25KW ECATRON WITH ELECTRONIC ON BOARD

TABLE OF PRODUCT CODES

MOT1504003	6P MOTOR 0.37KW ECATRON WITH ELECTRONIC ON BOARD
MOT1504004	6P MOTOR 0,55KW ECATRON WITH ELECTRONIC ON BOARD
MOT1504005	6P MOTOR 0.75KW ECATRON WITH ELECTRONIC ON BOARD
MOT1504006	6P MOTOR 1.10KW ECATRON WITH ELECTRONIC ON BOARD
MOT1504020	6P MOTOR 0.18KW ECATRON SEPARATE ELECTRONIC
MOT1504021	6P MOTOR 0.25KW ECATRON SEPARATE ELECTRONIC
MOT1504022	6P MOTOR 0.37KW ECATRON SEPARATE ELECTRONIC
MOT1504023	6P MOTOR 0.55KW ECATRON SEPARATE ELECTRONIC
MOT1504024	6P MOTOR 0.75KW ECATRON SEPARATE ELECTRONIC
MOT1504025	6P MOTOR 1.10KW ECATRON SEPARATE ELECTRONIC
MOT3004001	LINEAR MOTOR KIT 380V FOR BELLS UP TO 60 KG (132 LB)
MOT3004002	LINEAR MOTOR KIT 220V FOR BELLS UP TO 30 KG (66 LB)
MOT3004003	LINEAR MOTOR KIT 380V FOR BELLS UP TO 100 KG (220 LB)
MOT3004004	LINEAR MOTOR KIT 220V FOR BELLS UP TO MAX 70 KG (154 LB)
MOT3004005	LINEAR MOTOR KIT 380V FOR BELLS UP TO MAX 250 KG (551 LB)
MOT3004006	LINEAR MOTOR KIT 220V FOR BELLS UP TO MAX 100 KG (220 LB)
MOT3004007	LINEAR MOTOR KIT 380V FOR BELLS UP TO MAX 400 KG (881 LB)
MOT3004008	LINEAR MOTOR KIT 220V FOR BELLS UP TO MAX 400 KG (881 LB)
MOT3004009	LINEAR MOTOR KIT 380V FOR BELLS UP TO MAX 700KG (1543 LB)
MOT3004010	LINEAR MOTOR KIT 380V FOR BELLS UP TO MAX 1000 KG (2204 LB)
MOT3004011	LINEAR MOTOR KIT 380V FOR BELLS UP TO MAX 1300 KG (2866 LB)
MOT3004012	LINEAR MOTOR KIT 380V FOR BELLS UP TO 2500 KG (5511 LB)
RID0504001	GEAR BOX 1:20 1 CAM
RID0504002	GEAR BOX 1:20 2 CAMS
RID0504003	GEAR BOX 1:20 3 CAMS
RID0504004	GEAR BOX 1:20 4 CAMS
RID1004001	GEAR BOX 1:32 1 CAM CONCERT
RID1004002	GEAR BOX 1:32 2 CAMS CONCERT
RID1004003	GEAR BOX 1:32 3 CAMS CONCERT
RID1004004	GEAR BOX 1:32 4 CAMS CONCERT
RID1004005	GEAR BOX 1:32 6 CAMS CONCERT
RID1504001	GEAR BOX 1:8 1 CAM
RID1504002	GEAR BOX 1:8 2 CAMS
RID1504003	GEAR BOX 1:8 3 CAMS
RID1504004	GEAR BOX 1:8 4 CAMS
PIG-Z10/14/316	SPROCKET Z10 D.14X3/16"

TABLE OF PRODUCT CODES

PIG-Z10/14/516	SPROCKET Z10 D.14X5/16"
PIG-Z11/14/316	SPROCKET Z11 D.14X3/16"
PIG-Z11/14/516	SPROCKET Z11 D.14X5/16"
PIG-Z12/14/316	SPROCKET Z12 D.14X3/16"
PIG-Z12/14/516	SPROCKET Z12 D.14X5/16"
PIG-Z12/19/316	SPROCKET Z12 D.19X3/16"
PIG-Z12/19/516	SPROCKET Z12 D.19X5/16"
PIG-Z14/14/316	SPROCKET Z14 D.14X3/16"
PIG-Z14/14/515	SPROCKET Z14 D.14X5/16"
PIG-Z14/19/316	SPROCKET Z14 D.19X3/16"
PIG-Z14/19/516	SPROCKET Z14 D.19X5/16"
PIG-Z14/24/316	SPROCKET Z14 D.24X3/16"
PIG-Z14/24/516	SPROCKET Z14 D.24X5/16"
PIG-Z16/14/316	SPROCKET Z16 D.14X3/16"
PIG-Z16/14/516	SPROCKET Z16 D.14X5/16"
PIG-Z16/19/316	SPROCKET Z16 D.19X3/16"
PIG-Z16/19/516	SPROCKET Z16 D.19X5/16"
PIG-Z16/24/316	SPROCKET Z16 D.24X3/16"
PIG-Z16/24/516	SPROCKET Z16 D.24X5/16"
PIG-Z18/14/316	SPROCKET Z18 D.14X3/16"
PIG-Z18/14/516	SPROCKET Z18 D.14X5/16"
PIG-Z18/19/316	SPROCKET Z18 D.19X3/16"
PIG-Z18/19/516	SPROCKET Z18 D.19X5/16"
PIG-Z18/24/316	SPROCKET Z18 D.24X3/16"
PIG-Z18/24/516	SPROCKET Z18 D.24X5/16"
PIG-Z18/28/516	SPROCKET Z18 D.28X5/16"
PIG-Z21/19/316	SPROCKET Z21 D.19X3/16"
PIG-Z21/19/516	SPROCKET Z21 D.19X5/16"
PIG-Z21/24/316	SPROCKET Z21 D.24X3/16"
PIG-Z21/24/516	SPROCKET Z21 D.24X5/16"
PIG-Z21/28/516	SPROCKET Z21 D.28X5/16"
PIG-Z24/19/316	SPROCKET Z24 D.19X3/16"
PIG-Z24/19/516	SPROCKET Z24 D.19X5/16"
PIG-Z24/24/316	SPROCKET Z24 D.24X3/16"
PIG-Z24/24/516	SPROCKET Z24 D.24X5/16"

TABLE OF PRODUCT CODES

PIG-Z24/28/516	SPROCKET Z24 D.28X5/16"
PIG-Z26/28/516	SPROCKET Z26 D.28X5/16"
PIG-Z28/28/516	SPROCKET Z28 D.28X5/16"
PIG-Z30/28/516	SPROCKET Z30 D.28X5/16"
PIG-Z32/28/516	SPROCKET Z32 D.28X5/16"
PIG-Z34/28/516	SPROCKET Z34 D.28X5/16"
PIG-Z36/28/516	SPROCKET Z36 D.28X5/16"
PIG-Z38/28/516	SPROCKET Z38 D.28X5/16"
PIG-Z40/28/516	SPROCKET Z40 D.28X5/16"
PIG-Z8/11/316	SPROCKET Z8 D.11X3/16"
PIG-Z9/11/316	SPROCKET Z8 D.11X3/16"
MOT2004001	VARIANT C 10MF MOTOR 0.12KW 6P POWER 220V
MOT2004002	VARIANT C 16MF MOTOR 0.18KW 6P POWER 220V
MOT2004003	VARIANT C 25MF MOTOR 0.25KW 6P POWER 220V
MOT2004004	VARIANT C 35MF MOTOR 0.37KW 6P POWER 220V
MOT2004005	VARIANT C 50MF MOTOR 0.55KW 6P POWER 220V
MOT2004006	VARIANT C 50MF MOTOR 0.75KW 6P POWER 220V
MOT2004007	VARIANT C 76MF MOTOR 1.10KW 6P POWER 220V
MOT2004008	VARIANT C 76+35MF MOTOR 1.50KW 6P POWER 220V
MOT2004009	VARIANT C 76+50MF MOTOR 1.70KW 6P POWER 220V
MOT8001001	PROGRAMMING TERMINAL FOR ECATRON MOTOR
MOT8504001	FIXING BRACKET FOR MOTOR 0.12KW
MOT8504002	FIXING BRACKET FOR MOTOR 0.18-0.25KW
MOT8504003	FIXING BRACKET FOR MOTOR 0.37-0.55KW
MOT8504004	FIXING BRACKET FOR MOTOR 0.75-1.10KW
MOT8504005	FIXING BRACKET FOR MOTOR 1.5-1.70KW
MOT8504006	FIXING BRACKET FOR VOLTEO MOTOR UP TO 0.75 KW
MOT8504007	FIXING BRACKET FOR VOLTEO MOTOR > 0.75 KW
MOT9004035	PROGRAMMING TERMINAL FOR LINEAR MOTORS

ACCESSORIES

TABLE OF PRODUCT CODES

SWINGING BELLS / MOVIMIENTO CAMPANAS