

CLAPPERS / BADAJOS

BAT15-20

A clapper is the swinging device that, fixed inside the bell, enables to generate the sound by striking against the bell. It is usually manufactured in ductile iron to avoid an excessive consumption of the bell at the point of impact. It could be ordered also provided with cable seals and safety bracket in leather.

El badajo es el elemento que cuelga en el interior de la campana y que al moverse y golpear sus paredes hace que suenen. Se fabrica con hierro dulce para evitar un excesivo desgaste de la campana en el punto de impacto. También está disponible provisto de pasacables y retención de seguridad.

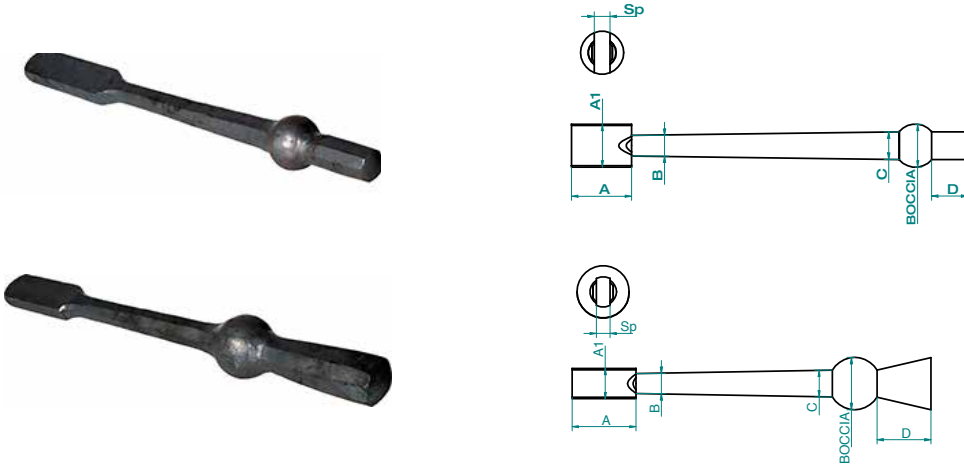

CODE	DESCRIPTION
BAT1504010	FALLING CLAPPER FOR BELL L 240
BAT1504011	FALLING CLAPPER FOR BELL L 270
BAT1504012	FALLING CLAPPER FOR BELL L310
BAT1504013	FALLING CLAPPER FOR BELL L 340
BAT1504014	FALLING CLAPPER FOR BELL L 385
BAT1504015	FALLING CLAPPER FOR BELL L 430
BAT1504016	FALLING CLAPPER FOR BELL L 480
BAT1504017	FALLING CLAPPER FOR BELL L 530
BAT1504018	FALLING CLAPPER FOR BELL L 580
BAT1504019	FALLING CLAPPER FOR BELL L 650
BAT1504020	FALLING CLAPPER FOR BELL L 730
BAT1504021	FALLING CLAPPER FOR BELL L 810
BAT1504022	FALLING CLAPPER FOR BELL L 870
BAT1504023	FALLING CLAPPER FOR BELL L 950
BAT1504024	FALLING CLAPPER FOR BELL L 1020
BAT1504025	FALLING CLAPPER FOR BELL L 1100
BAT1504026	FALLING CLAPPER FOR BELL L 1150
BAT2004010	FLYING CLAPPER FOR BELL L 240
BAT2004011	FLYING CLAPPER FOR BELL L 270
BAT2004012	FLYING CLAPPER FOR BELL L 310
BAT2004013	FLYING CLAPPER FOR BELL L 340
BAT2004014	FLYING CLAPPER FOR BELL L 385
BAT2004015	FLYING CLAPPER FOR BELL L 430
BAT2004016	FLYING CLAPPER FOR BELL L 480

CLAPPERS / BADAJOS

BAT15-20

BAT2004017	FLYING CLAPPER FOR BELL L 530
BAT2004018	FLYING CLAPPER FOR BELL L 580
BAT2004019	FLYING CLAPPER FOR BELL L 650
BAT2004020	FLYING CLAPPER FOR BELL L 730
BAT2004021	FLYING CLAPPER FOR BELL L 810
BAT2004022	FLYING CLAPPER FOR BELL L 860
BAT2004023	FLYING CLAPPER FOR BELL L 910
BAT2004024	FLYING CLAPPER FOR BELL L 1020
BAT2004025	FLYING CLAPPER FOR BELL L 1100
BAT2004026	FLYING CLAPPER FOR BELL L 1150

TABLE FOR BELL "FALLING CLAPPER" / TABLA CAMPANAS DE BANDEO CONTRAPESADO

BAT15

CODE	DESCRIPTION	BELL WEIGHT (Kg)	lb	TONE	ANGLO-SAXON TONE	L (mm) from the end of the tongue to the center of the head
BAT1504010	FALLING CLAPPER FOR BELL L 240	16 19	35,27 41,89	Mib RE	Dis3 D3	240
BAT1504011	FALLING CLAPPER FOR BELL L 270	22 26	48,50 57,32	Reb DO	Cis3 C3	270
BAT1504012	FALLING CLAPPER FOR BELL L310	31 37	68,34 81,57	SI Sib	B2 Ais2	310
BAT1504013	FALLING CLAPPER FOR BELL L 340	43 50	94,80 110,23	LA Lab	A2 Gis2	340
BAT1504014	FALLING CLAPPER FOR BELL L 385	60 72	132,28 158,73	SOL SOLb	G2 Fis2	385
BAT1504015	FALLING CLAPPER FOR BELL L 430	85 100	187,39 220,46	FA MI	F2 E2	430
BAT1504016	FALLING CLAPPER FOR BELL L 480	120 140	264,55 308,65	Mib RE	Dis2 D2	480
BAT1504017	FALLING CLAPPER FOR BELL L 530	170 200	374,79 440,92	Reb DO	Cis2 C2	540
BAT1504018	FALLING CLAPPER FOR BELL L 580	245	540,13	SI	B1	580
BAT1504019	FALLING CLAPPER FOR BELL L 650	290 340	639,34 749,57	Sib LA	Ais1 A1	650
BAT1504020	FALLING CLAPPER FOR BELL L 730	410 480	903,90 1058,22	Lab SOL	Gis1 G1	730
BAT1504021	FALLING CLAPPER FOR BELL L 810	550 680	1212,54 1499,14	SOLb FA	Fis1 F1	810
BAT1504022	FALLING CLAPPER FOR BELL L 870	810	1785,74	MI	E1	870
BAT1504023	FALLING CLAPPER FOR BELL L 950	980	2160,53	Mib	Dis1	950
BAT1504024	FALLING CLAPPER FOR BELL L 1020	1200 1400	2645,55 3086,47	RE Reb	D1 Cis1	1020
BAT1504025	FALLING CLAPPER FOR BELL L 1100	1680	3703,77	DO	C1	1100
BAT1504026	FALLING CLAPPER FOR BELL L 1150	1950	4299,01	SI	B0	1150

TABLE FOR BELL "FLYING CLAPPER" / TABLA CAMPANAS DE BANDEO
BAT20

CODE	DESCRIPTION	BELL WEIGHT (Kg)	lb	TONE	ANGLO-SAXON TONE	L (mm) from the end of the tongue to the center of the head
BAT2004010	FLYING CLAPPER FOR BELL L 240	16 19	35,27 41,89	Mib RE	Dis3 D3	240
BAT2004011	FLYING CLAPPER FOR BELL L 270	22 26	48,50 57,32	Reb D0	Cis3 C3	270
BAT2004012	FLYING CLAPPER FOR BELL L 310	31 37	68,34 81,57	SI Sib	B2 Ais2	310
BAT2004013	FLYING CLAPPER FOR BELL L 340	43 50	94,80 110,23	LA Lab	A2 Gis2	340
BAT2004014	FLYING CLAPPER FOR BELL L 385	60 72	132,28 158,73	SOL SOLb	G2 Fis2	385
BAT2004015	FLYING CLAPPER FOR BELL L 430	85 100	187,39 220,46	FA MI	F2 E2	430
BAT2004016	FLYING CLAPPER FOR BELL L 480	120 140	264,55 308,65	Mib RE	Dis2 D2	480
BAT2004017	FLYING CLAPPER FOR BELL L 530	170 200	374,79 440,92	Reb D0	Cis2 C2	540
BAT2004018	FLYING CLAPPER FOR BELL L 580	245	540,13	SI	B1	580
BAT2004019	FLYING CLAPPER FOR BELL L 650	290 340	639,34 749,57	Sib LA	Ais1 A1	650
BAT2004020	FLYING CLAPPER FOR BELL L 730	410 480	903,90 1058,22	Lab SOL	Gis1 G1	730
BAT2004021	FLYING CLAPPER FOR BELL L 810	550 680	1212,54 1499,14	SOLb FA	Fis1 F1	810
BAT2004022	FLYING CLAPPER FOR BELL L 860	810	1785,74	MI	E1	870
BAT2004023	FLYING CLAPPER FOR BELL L 910	980	2160,53	Mib	Dis1	950
BAT2004024	FLYING CLAPPER FOR BELL L 1020	1200 1400	2645,55 3086,47	RE Reb	D1 Cis1	1020
BAT2004025	FLYING CLAPPER FOR BELL L 1100	1680	3703,77	D0	C1	1100
BAT2004026	FLYING CLAPPER FOR BELL L 1150	1950	4299,01	SI	B0	1150

N.B. In order to choose a clapper, please refer to the length (L) in mm measured from the handle below (eyelet) to the striking point inside the bell.

Nota: Para seleccionar el badajo se toma como referencia la longitud (L) en mm medida desde debajo de la manilla (ojal) hasta el punto de golpe dentro de la campana.

CHAINS AND ACCESSORIES / CADENAS Y ACCESORIOS

RANGE OF PRODUCTS ESSENTIAL FOR TRANSMITTING THE MOVEMENT FROM MOTOR TO BELL
 PRODUCTOS NECESARIOS PARA LA TRANSMISIÓN DEL MOVIMIENTO DEL MOTOR A LA CAMPANA

CODE	DESCRIPTION
CAT3/16RIN	CHAIN 3/16" ½" STRENGTHENED
CAT3/16RIN - GIU	JOINT FOR CHAIN 3/16" STRENGTHENED
CAT5/16RIN	CHAIN 5/16" ½"
CAT5/16RIN - GIU	JOINT FOR CHAIN 5/16"
MOT8504008	CHAIN TIGHTENER FLYING CLAPPER SYST.-MOTOR UP TO 0.55KW
MOT8504009	CHAIN TIGHTENER FLYING CLAPPER SYST.-MOTOR UP TO 1.50KW
MOT8504010	CHAIN TIGHTENER FALLING CLAPPER SYST.-MOTOR UP TO 0.37KW
MOT8504011	CHAIN TIGHTENER FALLING CLAPPER SYST.-MOTOR UP TO 0.75KW
MOT8504012	CHAIN TIGHTENER FALLING CLAPPER SYST.-MOTOR UP TO 1.50KW

BELL ELECTRIFICATION / ELECTRIFICACIÓN CAMPANAS

RANGE OF PRODUCTS REQUIRED FOR BELL INSTALLATION AND MOVEMENT WITHIN THE BELL TOWER
 LISTA DE LOS PRODUCTOS NECESARIOS PARA SOSTENER Y MOVER LA CAMPANA DENTRO DE LA CELDA CAMPANARIA

COMPLETE SWINGING BELL CAMPANA DE VOLTEO

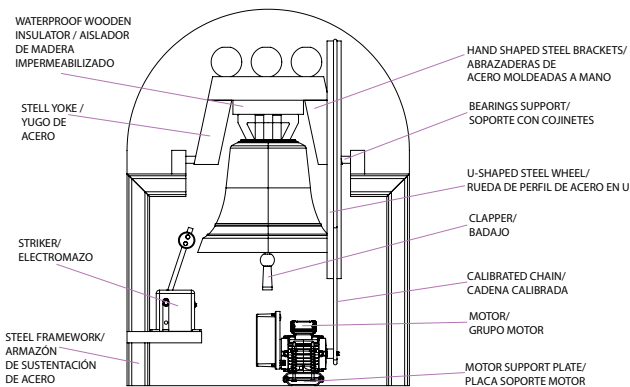

FALLING CLAPPER BELL CAMPANA DE BANDEO CONTRAPESADO

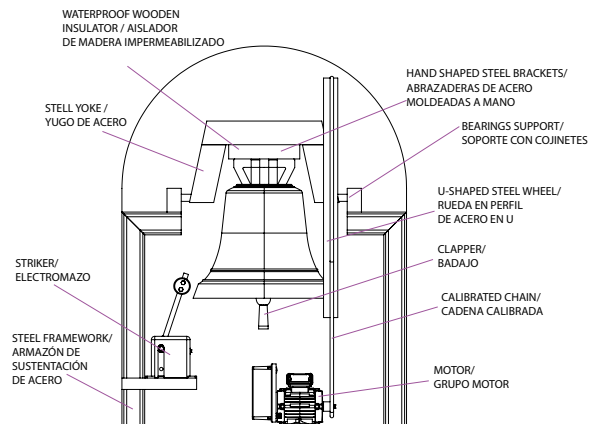

LINEAR MOTOR BELL SYSTEM CAMPANA CON MOTOR LINEAL

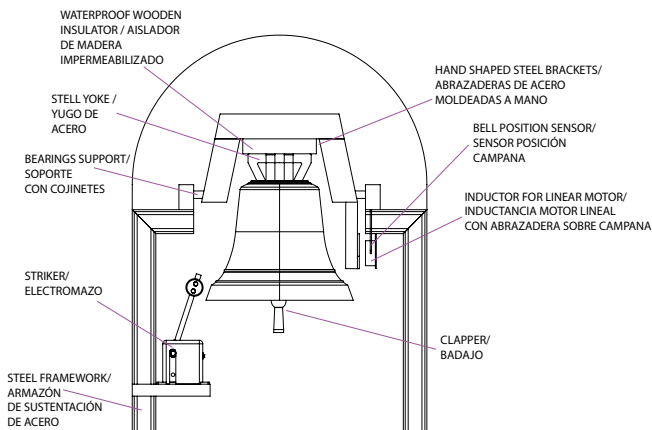

FLYING CLAPPER BELL CAMPANA DE BANDEO

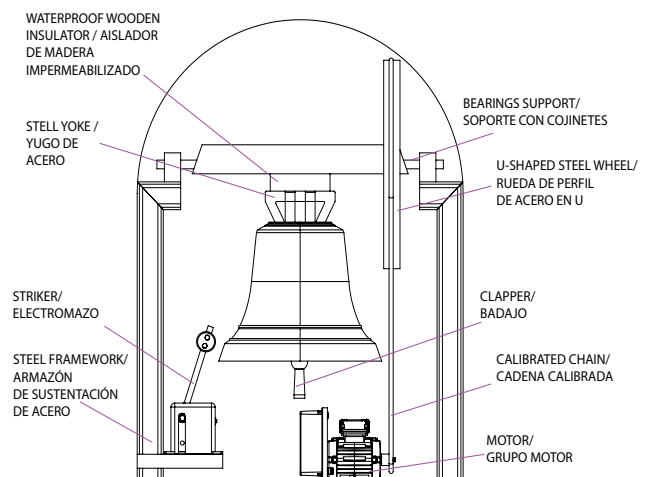

TABLE OF PRODUCT CODES

CODE	DESCRIPTION
BAT1504010	FALLING CLAPPER FOR BELL L 240
BAT1504011	FALLING CLAPPER FOR BELL L 270
BAT1504012	FALLING CLAPPER FOR BELL L310
BAT1504013	FALLING CLAPPER FOR BELL L 340
BAT1504014	FALLING CLAPPER FOR BELL L 385
BAT1504015	FALLING CLAPPER FOR BELL L 430
BAT1504016	FALLING CLAPPER FOR BELL L 480
BAT1504017	FALLING CLAPPER FOR BELL L 530
BAT1504018	FALLING CLAPPER FOR BELL L 580
BAT1504019	FALLING CLAPPER FOR BELL L 650
BAT1504020	FALLING CLAPPER FOR BELL L 730
BAT1504021	FALLING CLAPPER FOR BELL L 810
BAT1504022	FALLING CLAPPER FOR BELL L 870
BAT1504023	FALLING CLAPPER FOR BELL L 950
BAT1504024	FALLING CLAPPER FOR BELL L 1020
BAT1504025	FALLING CLAPPER FOR BELL L 1100
BAT1504026	FALLING CLAPPER FOR BELL L 1150
BAT2004010	FLYING CLAPPER FOR BELL L 240
BAT2004011	FLYING CLAPPER FOR BELL L 270
BAT2004012	FLYING CLAPPER FOR BELL L 310
BAT2004013	FLYING CLAPPER FOR BELL L 340
BAT2004014	FLYING CLAPPER FOR BELL L 385
BAT2004015	FLYING CLAPPER FOR BELL L 430
BAT2004016	FLYING CLAPPER FOR BELL L 480
BAT2004017	FLYING CLAPPER FOR BELL L 530
BAT2004018	FLYING CLAPPER FOR BELL L 580
BAT2004019	FLYING CLAPPER FOR BELL L 650
BAT2004020	FLYING CLAPPER FOR BELL L 730
BAT2004021	FLYING CLAPPER FOR BELL L 810
BAT2004022	FLYING CLAPPER FOR BELL L 860
BAT2004023	FLYING CLAPPER FOR BELL L 910
BAT2004024	FLYING CLAPPER FOR BELL L 1020
BAT2004025	FLYING CLAPPER FOR BELL L 1100
BAT2004026	FLYING CLAPPER FOR BELL L 1150
CAT3/16RIN	CHAIN 3/16" 1/2" STRENGTHENED
CAT3/16RIN-GIU	JOINT FOR CHAIN 3/16" STRENGTHENED
CAT5/16RIN	CHAIN 5/16" 1/2"
CAT5/16RIN-GIU	JOINT FOR CHAIN 5/16"

TABLE OF PRODUCT CODES

ACCESSORIES

MOT8504008	CHAIN TIGHTENER FOR FLYING CLAPPER SYST.-MOTOR UP TO 0.55KW
MOT8504009	CHAIN TIGHTENER FLYING CLAPPER SYST.-MOTOR UP TO 1.50KW
MOT8504010	CHAIN TIGHTENER FALLING CLAPPER SYST.-MOTOR UP TO 0.37KW
MOT8504011	CHAIN TIGHTENER FALLING CLAPPER SYST.-MOTOR UP TO 0.75KW
MOT8504012	CHAIN TIGHTENER FALLING CLAPPER SYST.-MOTOR UP TO 1.50KW
BAT2504001	COMPLETE SET LEATHER AND CLAMP L 40 MM
BAT2504002	COMPLETE SET LEATHER AND CLAMP L 50 MM
BAT2504003	COMPLETE SET LEATHER AND CLAMP L 60 MM
BAT2504004	COMPLETE SET LEATHER AND CLAMP L 70 MM
BAT2504005	COMPLETE SET LEATHER AND CLAMP L 80 MM
BAT2504006	COMPLETE SET LEATHER AND CLAMP L 90 MM
BAT2504007	COMPLETE SET LEATHER AND CLAMP L 100 MM
BAT3004001	COMPLETE SET LEATHER AND CLAMP ON REQUEST
CPP0504001	YOKE FOR FALLING CLAPPER SYSTEM FOR BELLS UP TO 55 CM
CPP0504002	YOKE FOR FALLING CLAPPER SYSTEM FOR BELLS 56 - 70 CM
CPP0504003	YOKE FOR FALLING CLAPPER SYSTEM FOR BELLS 71 - 95 CM
CPP0504004	YOKE FOR FALLING CLAPPER SYSTEM FOR BELLS 96 - 110 CM
CPP0504005	YOKE FOR FALLING CLAPPER SYSTEM FOR BELLS 111 - 155 CM
CPP1004001	YOKE FOR FLYING CLAPPER SYSTEM FOR BELLS UP TO 55 CM
CPP1004002	YOKE FOR FLYING CLAPPER SYSTEM FOR BELLS 56 - 70 CM
CPP1004003	YOKE FOR FLYING CLAPPER SYSTEM FOR BELLS 71 - 95 CM
CPP1004004	YOKE FOR FLYING CLAPPER SYSTEM FOR BELLS 96 - 110 CM
CPP1004005	YOKE FOR FLYING CLAPPER SYSTEM FOR BELLS 111 - 155 CM
CPP1504001	INSULATOR FOR YOKE 120 X 120
CPP1504002	INSULATOR FOR YOKE 130 X 130
CPP1504003	INSULATOR FOR YOKE 170 X 170
CPP1504004	INSULATOR FOR YOKE 200 X 200
CPP1504005	INSULATOR FOR YOKE 220 X 220
CPP1504006	INSULATOR FOR YOKE 270 X 270
CPP1504007	INSULATOR FOR YOKE 300 X 300
CPP1504008	INSULATOR FOR YOKE 350 X 350
CPP1504009	INSULATOR FOR YOKE ON REQUEST
CUS25SOP	BEARING WITH BUILT-IN SUPPORT D.25
CUS35SOP	BEARING WITH BUILT-IN SUPPORT D.35
CUS45SOP	BEARING WITH BUILT-IN SUPPORT D.45
CUS50SOP	BEARING WITH BUILT-IN SUPPORT D.50
FRR0504001	CLEVIS FOR BELL FIXING M16 H.165
FRR0504002	CLEVIS FOR BELL FIXING M18 H.165
FRR0504003	CLEVIS FOR BELL FIXING M20 H.180

TABLE OF PRODUCT CODES

BELLS-CHAINS-ACCESSORIES / BADAJOS – CADENAS – ACCESORIOS

TABLE OF PRODUCT CODES

ACCESSORIES

FRR0504004	CLEVIS FOR BELL FIXING M22 H.180
FRR0504005	CLEVIS FOR BELL FIXING M24 H.220
FRR0504006	CLEVIS FOR BELL FIXING M27 H.220
FRR0504008	CLEVIS FOR BELL FIXING M33 H.300
FRR0504010	CLEVIS FOR BELL FIXING ON REQUEST
FRR1004001	ROD FOR BELL FIXING M16 H.350
FRR1004002	ROD FOR BELL FIXING M18 H.350
FRR1004003	ROD FOR BELL FIXING M20 H.360
FRR1004004	ROD FOR BELL FIXING M24 H.400
FRR1004005	ROD FOR BELL FIXING M27 H.470
FRR1004006	ROD FOR BELL FIXING M30 H.500
FRR1004007	ROD FOR BELL FIXING M33 H.300
FRR1004010	ROD FOR BELL FIXING ON REQUEST
FRR1504001	CROSSBAR FOR BELL FIXING 80X27
FRR1504002	CROSSBAR FOR BELL FIXING 95X27
FRR1504003	CROSSBAR FOR BELL FIXING 120X30
FRR1504004	CROSSBAR FOR BELL FIXING 130X30
FRR1504005	CROSSBAR FOR BELL FIXING 160X35
FRR1504006	CROSSBAR FOR BELL FIXING 180X35
FRR1504007	CROSSBAR FOR BELL FIXING 260X55
FRR1504010	CROSSBAR FOR BELL FIXING ON REQUEST
INC0504001	FRAME FOR BELLS ON REQUEST - KG
RU00504001	BELL WHEEL FOR FALLING CLAPPER SYSTEM BELLS UP TO 55 CM
RU00504002	BELL WHEEL FOR FALLING CLAPPER SYSTEM BELLS 56 -71CM
RU00504003	BELL WHEEL FOR FALLING CLAPPER SYSTEM BELLS 71 - 95 CM
RU00504004	BELL WHEEL FOR FALLING CLAPPER SYSTEM BELLS 95 -110 CM
RU00504005	BELL WHEEL FOR FALLING CLAPPER SYSTEM BELLS 111 - 155 CM
RU01004001	BELL WHEEL FOR FLYING CLAPPER SYSTEM BELLS UP TO 55 CM
RU01004002	BELL WHEEL FOR FLYING CLAPPER SYSTEM BELLS 56 -70 CM
RU01004003	BELL WHEEL FOR FLYING CLAPPER SYSTEM BELLS 71 - 95 CM
RU01004004	BELL WHEEL FOR FLYING CLAPPER SYSTEM BELLS 96 -110 CM
RU01004005	BELL WHEEL FOR FLYING CLAPPER SYSTEM BELLS 111 - 155 CM
RU01504001	STEEL CIRCLE DIAMETER UP TO 100 CM
RU01504002	STEEL CIRCLE DIAMETER UP 100 - 150 CM
RU01504003	STEEL CIRCLE DIAMETER 150 - 200 CM
SUP0504025	BEARING AND CAST IRON SUPPORT KIT D.25
SUP0504035	BEARING AND CAST IRON SUPPORT KIT D.35
SUP0504045	BEARING AND CAST IRON SUPPORT KIT D.45
SUP0504050	BEARING AND CAST IRON SUPPORT KIT D.50